



Series
DSX

SIZE 22 CRIMP PIN CONTACT
WIRE SIZE AWG 22-24-26

Issue:
23 FEB 99

Page
1 / 1

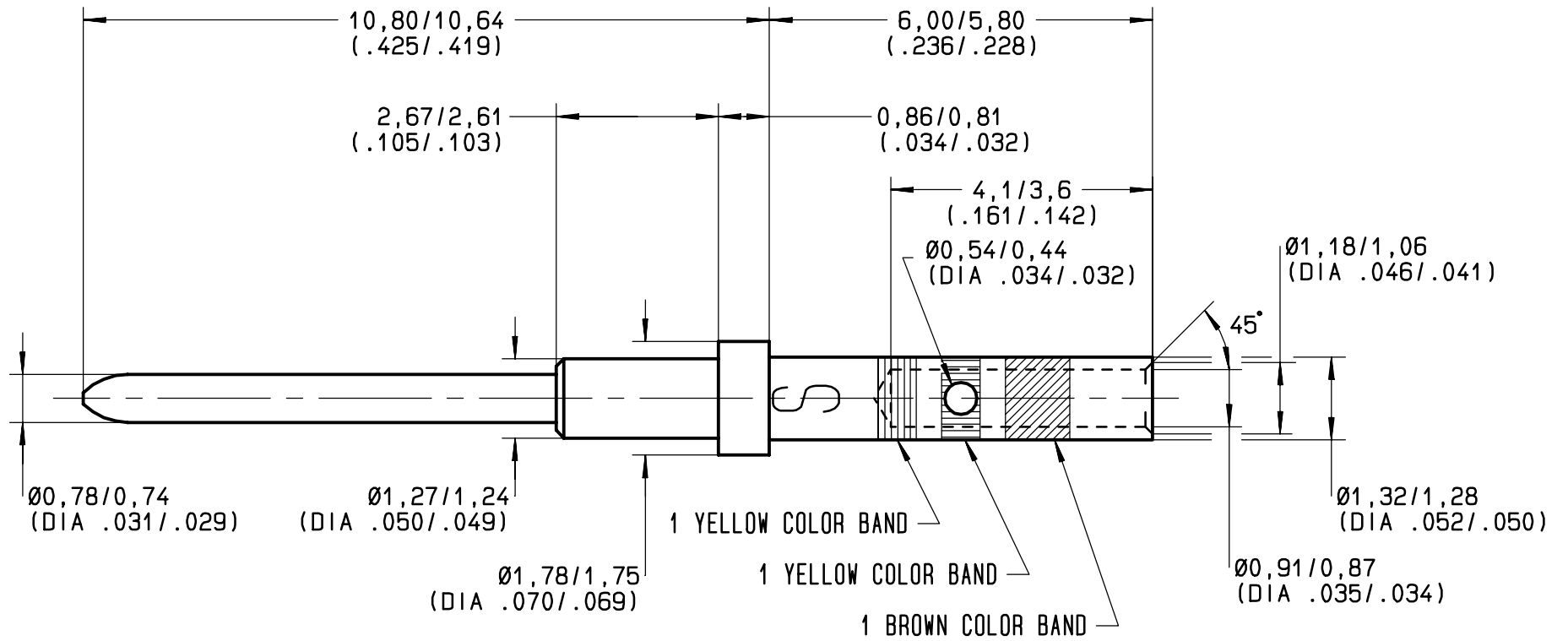

MATERIAL: COPPER ALLOY (C97) HARDNESS IN KNOOP 120 MAX (107 HV) FOR CRIMP BARREL
180 MIN (165 HV) FOR BEYOND SHOULDER

FINISH: GOLD PER MIL-G-45204 TYPE I OR II GRADE C OR D CLASS 1 50 MICROINCHES OVER NICKEL PLATE PER QQ-N-290

WIRES ACCOMODATED: AWG 22-24-26
INSULATOR DIAMETER: .055 MAX (1,40)
STRIP LENGTH: .138 (3,50)

CRIMP CONTACT TENSILE REQUIREMENTS USING MIL SPEC TOOLING AND WIRE SPEC
M22520/2-01 22 GA. 11 LBS (5,5 daN)

CRIMPED CONTACTS WILL SHOW NO CRACK WHEN INSPECTED PER MIL-C-22520 AT 10X

RADIALL TOOLING RECOMMENDATION
CRIMPING TOOL: M22520/2-01 (RADIALL 282 281)
SELECTOR POSITION: 4 FOR AWG 22
3 FOR AWG 24
3 FOR AWG 26
POSITIONER: M22520/2-23 (RADIALL 282 970)

INSERTION/EXTRACTION TOOL: M81969/1-01 (RADIALL 282 885)
SPL RADIALL INS. 282 880 / EXT. 282 890

This information is given as an indication. In the continual goal to improve our products, we reserve the right to make any modifications judged necessary.

4112-9311

CREATION				
PEN:				
NOM: MACARI				
DATE: 29 MAY 80				
APPR.:	23 FEB 99	REDRAWN	VALGRESY	.
	Issue	Revisions	Name	Approved